



DATA SHEET

HIGH CURRENT ZERO OHM JUMPER PA series

sizes 0100/ 0201/ 0402/ 0603/ 0805/ 1206/ 2010

RoHS compliant & Halogen free

顺海科技
0755-28100016





SCOPE

This specification describes PA0100~2010 series jumper with metal alloy layer.

APPLICATIONS

- Consumer goods
- Computer
- Telecom / Datacom
- Industrial / Power supply
- Alternative Energy
- Car electronics

FEATURES

- PA Jumper resistors are designed to be used as a zero ohm jumper
- AEC-Q200 qualified
- Halogen-free Epoxy
- RoHS compliant
- Reduce environmentally hazardous wastes
- High component and equipment reliability
- Non-forbidden materials used in products/production
- High current capability
- Moisture sensitivity level: MSL 1

ORDERING INFORMATION - GLOBAL PART NUMBER

Global part numbers are identified by the series, size, tolerance, packing type, temperature coefficient, taping reel and resistance value.

GLOBAL PART NUMBER

PA **XXXX** **X** **X** **X** **XX** **OR** **L**
(1) (2) (3) (4) (5) (6) (7)

(1) SIZE

0100 / 0201 / 0402 / 0603 / 0805 / 1206 / 2010

(2) TOLERANCE

-

(3) PACKAGING TYPE

R = Paper taping reel (PA0100~1206)
 K = Embossed taping reel (PA2010)

(4) TEMPERATURE COEFFICIENT OF RESISTANCE

-

(5) TAPING REEL

07 = 7 inch dia. Reel
 7W = 7 inch dia. Reel, (0402 only)
 47 = 7 inch dia. Reel, (0805 only)

(6) RESISTANCE VALUE

0R = 0 Ω

(7) DEFAULT CODE

Letter L is the system default code for ordering only. (Note)

Resistance rule of global part number

Resistance code rule	Example
0R (0 Ω)	0R = 0 Ω

ORDERING EXAMPLE

The ordering code for a PA0603 chip resistor, value 0 Ω, supplied in 7-inch tape reel with 5Kpcs quantify is: PA0603-R-070RL.

NOTE

1. All our RChip products are RoHS compliant. "LFP" of the internal 2D reel label mentions "Lead-Free Process"



MARKING

PA0201

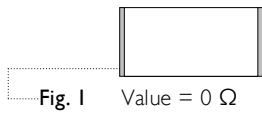

No Marking

Fig. 1 Value = 0 Ω

PA0100 / 0402 / 0603 / 0805 / 1206 / 2010



No Marking

Fig. 2 Value = 0 Ω

CONSTRUCTION

The advanced resistive material is adopted to get the low resistance and is covered with a protective coat. Finally, the three external terminations (Cu / Ni / matte Tin) are added, as shown in Fig. 3.

Outlines

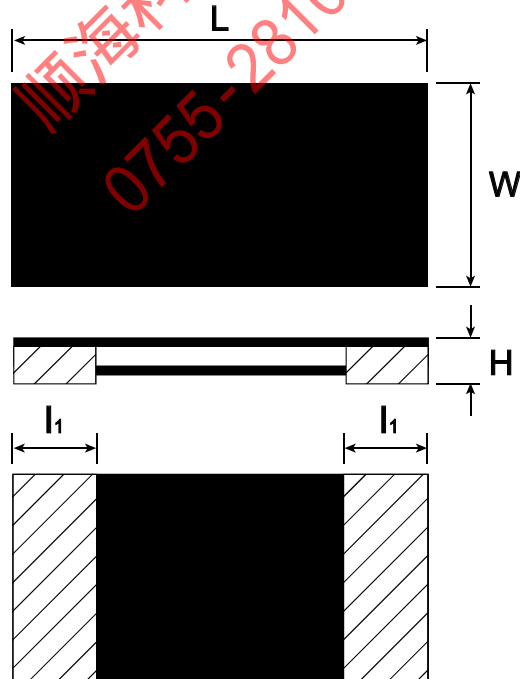

Fig. 3 Chip resistor outlines



DIMENSION

Table 1 For outlines, please refer to Fig. 3

TYPE	L (mm)	W (mm)	H (mm)	l ₁ (mm)
PA0100	0.40±0.03	0.20±0.03	Max. 0.15	0.10±0.03
PA0201	0.60±0.03	0.31±0.04	Max. 0.35	0.15±0.06
PA0402	1.00±0.10	0.55±0.10	Max. 0.35	0.25±0.10
PA0603	1.60±0.20	0.8+0.10/-0.20	0.45±0.15	0.38±0.12
PA0805	2.00±0.15	1.20±0.15	Max. 0.40	0.35±0.25
PA1206	3.05±0.20	1.52±0.20	0.50±0.20	0.70±0.20
PA2010	5.08±0.20	2.54±0.20	0.40±0.15	0.70±0.20

Note:

1. For relevant physical dimensions, please refer to construction outlines.
2. Please contact with sales offices, distributors and representatives in your region before ordering.

ELECTRICAL CHARACTERISTICS

Table 2

		PA0100	PA0201	PA0402		PA0603	PA0805	PA1206	PA2010
Jumper Criteria	Resistance Value, Max. (mΩ)	<2mΩ	<5mΩ	<1mΩ	<0.2mΩ	<0.2mΩ	<0.5mΩ	≤0.2mΩ	≤0.2mΩ
	Rated Current (A)	8	4.5	11	23	50	20	70.7	100
	Rated Power (W)	1/8	1/10	1/8	1/10	1/2	1/5	1	2
Operating Temperature Range		-55°C to +125°C				-55°C to +155°C		-55°C to +170°C	

Note: Please contact with sales offices, distributors and representatives in your region before ordering.

FUNCTIONAL DESCRIPTION

OPERATING TEMPERATURE RANGE

PA0100 to PA0402: -55°C to +125°C
 PA0603/ PA0805: -55°C to +155°C
 PA1206/ PA2010: -55°C to +170°C

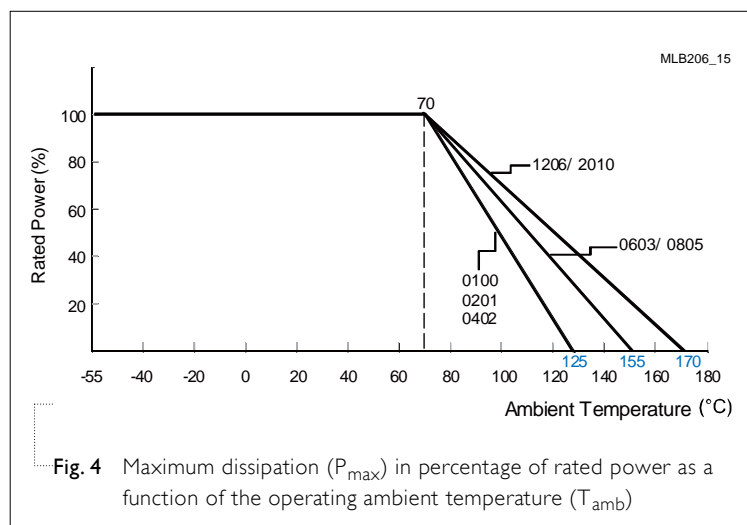

Fig. 4 Maximum dissipation (P_{max}) in percentage of rated power as a function of the operating ambient temperature (T_{amb})



PACKING STYLE AND PACKAGING QUANTITY

Table 3 Packing style and packaging quantity

PACKING STYLE	REEL DIMENSION	PA0100	PA0201	PA0402	PA0603	PA0805	PA1206	PA2010
Paper taping reel (R)	7" (178 mm)	20,000	10,000	10,000	5,000	5,000	4000	---
Embossed Taping Reel (K)	7" (178 mm)	---	---	---	---	---	---	4000

PAPER TAPE

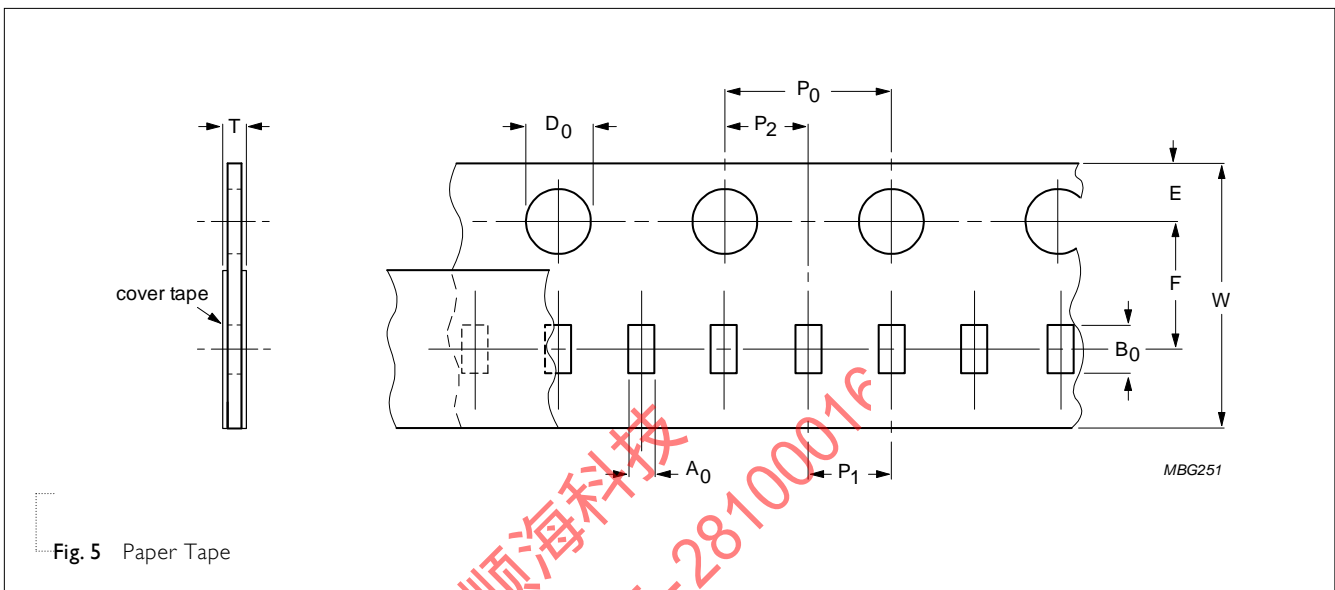

Fig. 5 Paper Tape

Table 4 Dimensions of paper tape for relevant chip resistors size

SIZE	SYMBOL										Unit: mm
	A ₀	B ₀	W	E	F	P ₀	P ₁	P ₂	ØD ₀	T	
PA0100	0.24±0.03	0.45±0.03	8.00±0.20	1.75±0.10	3.50±0.05	4.00±0.05	2.00±0.10	2.00±0.05	1.50±0.10	0.31±0.10	
PA0201	0.38±0.10	0.68±0.10	8.00±0.10	1.75±0.10	3.50±0.10	4.00±0.10	2.00±0.10	2.00±0.10	1.55±0.05	0.42±0.10	
PA0402	0.59±0.10	1.20±0.10	8.00±0.10	1.75±0.10	3.50±0.10	4.00±0.10	2.00±0.10	2.00±0.10	1.55±0.05	0.45±0.10	
PA0603	1.10±0.10	1.90±0.10	8.00±0.10	1.75±0.10	3.50±0.10	4.00±0.10	4.00±0.10	2.00±0.10	1.55±0.05	0.43±0.10	
PA0805	1.62±0.10	2.35±0.10	8.00±0.10	1.75±0.10	3.50±0.10	4.00±0.10	4.00±0.10	2.00±0.10	1.55±0.05	0.43±0.10	
PA1206	1.90±0.20	3.50±0.20	8.00±0.20	1.75±0.10	3.50±0.50	4.00±0.10	4.00±0.10	2.00±0.05	1.50±0.10	0.75+0.20/-0	



EMBOSSED TAPE

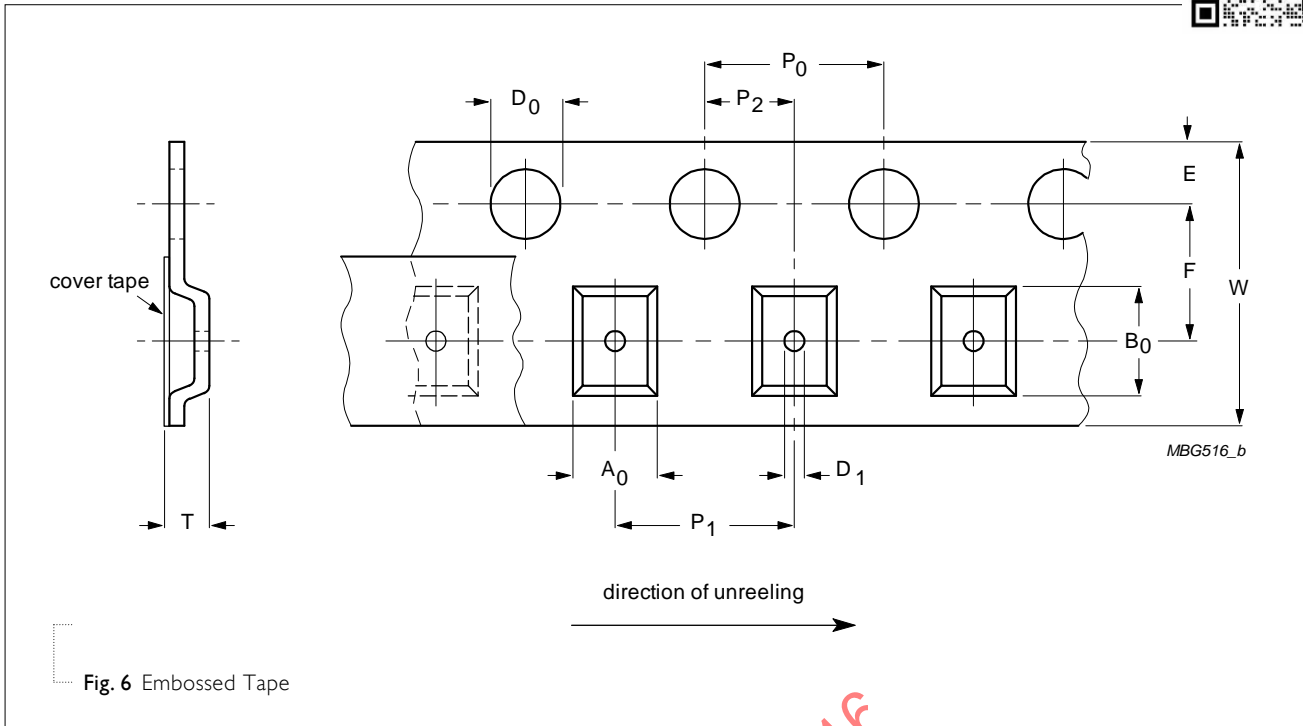

Fig. 6 Embossed Tape

Table 5 Dimensions of embossed tape for relevant chip resistors size

SIZE	SYMBOL										Unit: mm
	A ₀	B ₀	W	E	F	P ₀	P ₁	P ₂	ΦD ₀	ΦD ₁	
PA2010	3.40±0.15	6.70±0.15	12.0±0.30	1.75±0.10	5.50±0.10	4.00±0.10	4.00±0.10	2.00±0.10	1.50±0.10	1.50±0.10	0.80±0.15

顺海科技
 0755-28100016



REEL SPECIFICATION

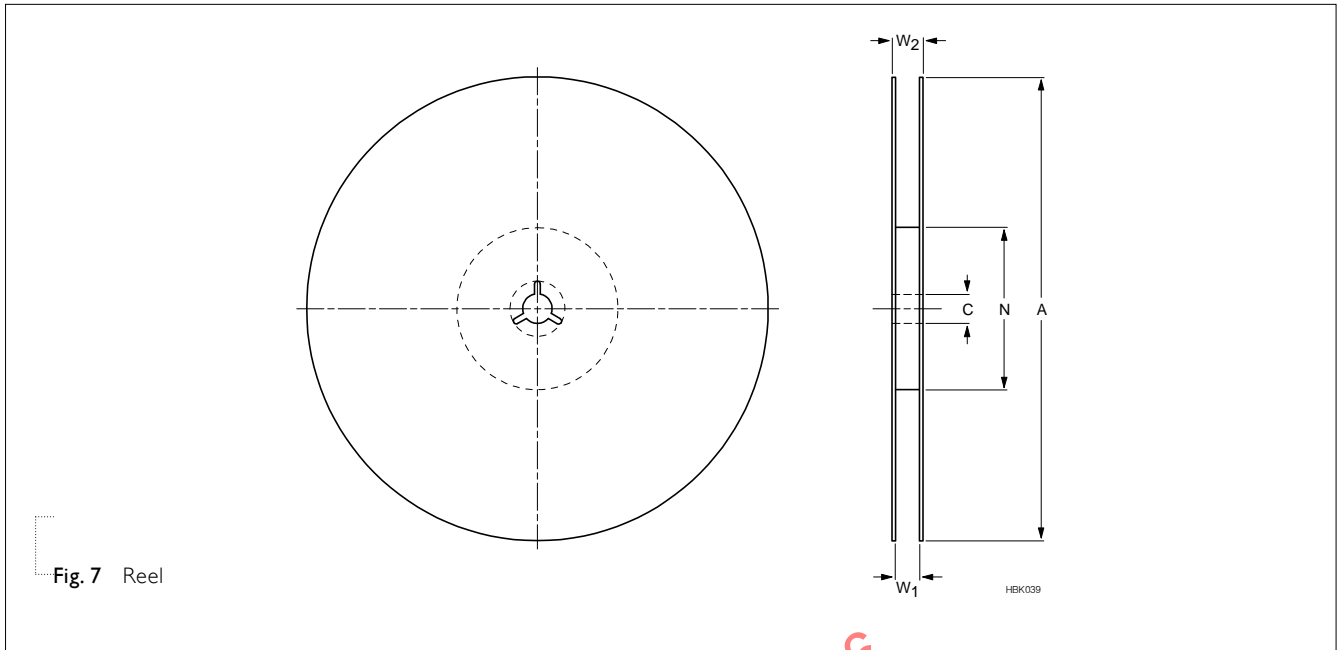

Table 6 Dimensions of reel specification for relevant chip resistors size

SIZE	QUANTITY PER REEL	REEL SIZE		SYMBOL	Unit: mm				
		8 mm TAPE WIDE	12 mm TAPE WIDE		A	N	C	D	W ₁
PA0100	20,000	7" (Ø 178 mm)	---	180.0+0/-3.0	60.0+1/-0	13.0± 0.2	21.0± 0.8	9.0± 0.3	11.4± 1.0
PA0201	10,000	7" (Ø 178 mm)	---	178.0± 1.0	60.0+1/-0	13.5± 0.5	21.0± 0.8	9.0± 0.5	12.0± 0.2
PA0402	10,000	7" (Ø 178 mm)	---	178.0± 1.0	60.0+1/-0	13.5± 0.5	21.0± 0.8	9.0± 0.5	12.0± 0.2
PA0603	5,000	7" (Ø 178 mm)	---	178.0± 1.0	60.0+1/-0	13.5± 0.5	21.0± 0.8	9.0± 0.5	12.0± 0.2
PA0805	5,000	7" (Ø 178 mm)	---	178.0± 1.0	60.0+1/-0	13.5± 0.5	21.0± 0.8	9.0± 0.5	12.0± 0.2
PA1206	4,000	7" (Ø 178 mm)	---	178.0± 1.0	60.0+1/-0	13.5± 0.5	21.0± 0.8	9.0± 0.5	12.0± 0.2
PA2010	4,000	---	7" (Ø 178 mm)	178.0± 1.0	60.0+1/-0	13.5± 0.5	21.0± 0.8	13.6± 0.5	16.5± 0.5

LEADER/TRAILER TAPE SPECIFICATION

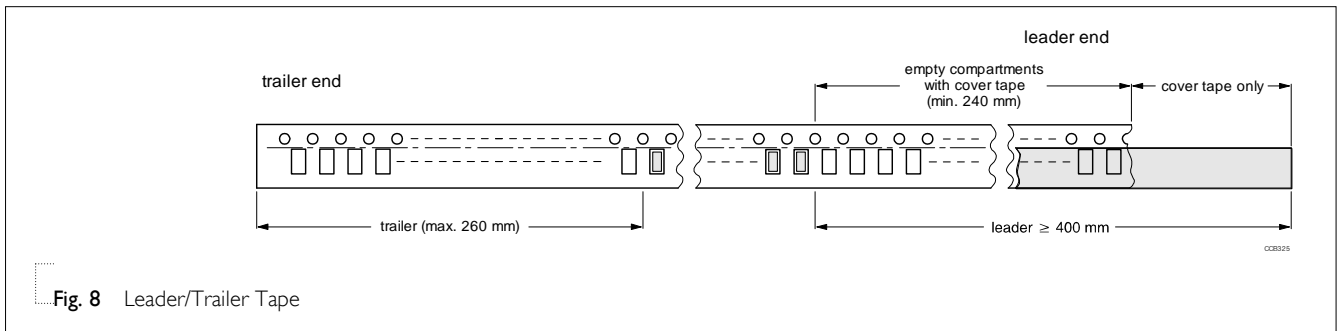

Fig. 8 Leader/Trailer Tape



FOOTPRINT AND SOLDERING PROFILES

For recommended soldering profiles, please refer to data sheet “Chip resistors mounting”.

FOOTPRINT

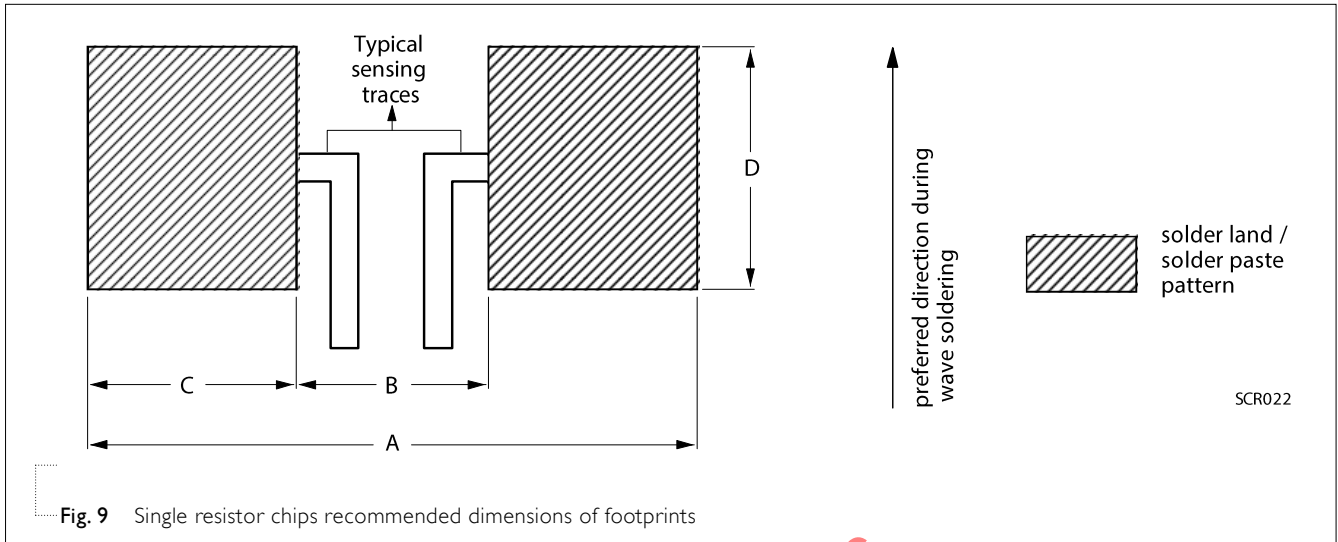

Fig. 9 Single resistor chips recommended dimensions of footprints

Table 7 Footprint dimensions

Unit: mm

SIZE	A	B	C	D
PA0100	0.5~0.8	0.16~0.2	0.17~0.3	0.2~0.4
PA0201	1.0	0.3	0.35	0.4
PA0402	2.0	0.4	0.8	0.6
PA0603	2.2	0.8	0.7	0.9
PA0805	3.4	0.8	1.3	1.3
PA1206	4.0	1.0	1.5	1.8
PA2010	6.0	3.5	1.25	3.0

0755-28100016
顺海科技



TESTS AND REQUIREMENTS

Table 8 Test condition, procedure and requirements

TEST	TEST METHOD	PROCEDURE	REQUIREMENT
Life/ Endurance	MIL-STD-202 Method 108	1,000 hours at 70±2°C applied RCWV	0100 : < 2mΩ
	IEC 60115-1 4.25.1	1.5 hours on, 0.5 hour off, still air required	0201 : < 5mΩ 0402 : < 1mΩ < 0.5mΩ Others : < 0.2mΩ
High Temperature Exposure/ Endurance at upper category temperature	MIL-STD-202 Method 108	1,000 hours, unpowered at	0100 : < 2mΩ
	IEC 60115-1 4.25.3	0100/ 0201/ 0402 : 125±5°C 0603/ 0805 : 155±5°C 1206/ 2010 : 170±5°C	0201 : < 5mΩ 0402 : < 1mΩ < 0.5mΩ Others : < 0.2mΩ
Moisture Resistance	MIL-STD-202 Method 106	Each temperature / humidity cycle is defined at 8 hours (Method 106G), 3 cycles / 24 hours for 10d. with 25 °C / 65 °C 95% R.H, without steps 7a & 7b, un-powered Parts mounted on test board, without condensation on parts Measurement at 24±2 hours after test conclusion.	0100 : < 2mΩ 0201 : < 5mΩ 0402 : < 1mΩ < 0.5mΩ Others : < 0.2mΩ No visible damage
Thermal Shock	MIL-STD-202 Method 107	-55/+125°C Note : Number of cycles required is 300. Parts mounted on test board. Maximum transfer time is 20 seconds. Dwell time is 15 minutes.	0100 : < 2mΩ 0201 : < 5mΩ 0402 : < 1mΩ < 0.5mΩ Others : < 0.2mΩ
Short time overload	IEC 60115-1 4.13	5 times rated power for 5 seconds.	0100 : < 2mΩ 0201 : < 5mΩ 0402 : < 1mΩ < 0.5mΩ Others : < 0.2mΩ No visible damage
Board Flex/ Bending	IEC 60115-1 4.33	Device mounted on PCB test board as described, only 1 board bending required Bending for 0100 : 5mm 0201 : 3 mm 0402 and above: 2mm Bending time: 60±1 seconds Ohmic value checked during bending	0100 : < 2mΩ 0201 : < 5mΩ 0402 : < 1mΩ < 0.5mΩ Others : < 0.2mΩ



TEST	TEST METHOD	PROCEDURE	REQUIREME
Solderability - Wetting	IPC/JEDEC J-STD-002B test B	Electrical Test not required Magnification 50X SMD conditions: 1st step : Method B, aging 4 hours at 155°C dry heat 2nd step : lead free solder bath at 245±3°C Dipping time : 3±0.5 seconds	Well tinned (>95% covered) No visible damage
- Leaching	IPC/JEDEC J-STD-002B test D	Lead free solder, 260°C, 30 seconds immersion time	No visible damage
- Resistance to Soldering Heat	MIL-STD-202 Method 210 IEC 60115-1 4.18	Condition B, no pre-heat of samples Lead free solder, 260±5°C, 10±1 seconds immersion time Procedure 2 for SMD: devices fluxed and cleaned with isopropanol	0100 : < 2mΩ 0201: < 5mΩ 0402: < 1mΩ < 0.5mΩ Others : < 0.2mΩ No visible damage

顺海科技
0755-28100016



REVISION HISTORY

REVISION	DATE	CHANGE NOTIFICATION	DESCRIPTION
Version 1	Jan. 27, 2021	-	- Add sizes of PA0100, PA1206 and PA2010
Version 0	Oct. 05, 2018	-	- Metal low ohmic jumper - PA series

顺海科技
 0755-28100016

“Yageo reserves all the rights for revising the content of this datasheet without further notification, as long as the products itself are unchanged. Any product change will be announced by PCN.”